

F1 操纵STEERING

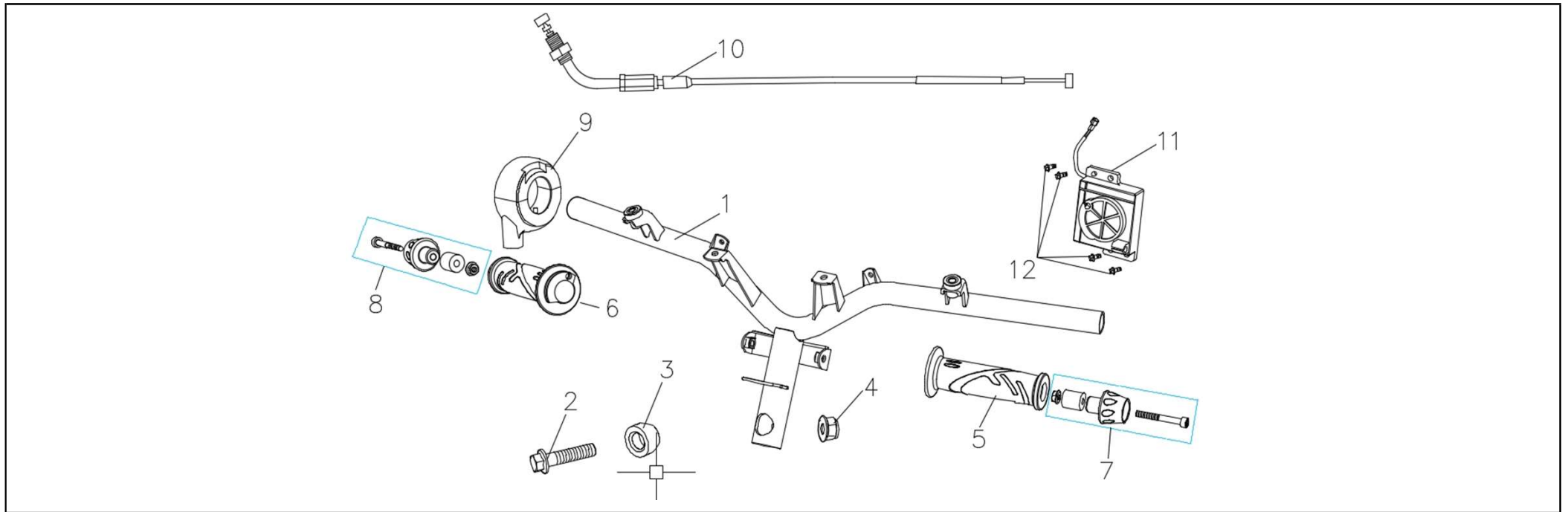

序号 No.	品号 Part No.	中文名称 Description	英文名称 Description	规格 SPCE.	单位 Unit	数量 Qty	备注 Remark
1	ES3420062	ES3420062	方向把 HANDLE COMP.	SW- F19,电泳黑,后视镜座左正右反牙	PCS	1	
2	YYB950QT05002	ES3230476	方向把锁紧螺栓,M10*1.25*48	FLANGE BOLT M10×1.25×48	三价白	PCS	1
3	QBC-45101-0000	ES3420039	方向把衬套	COLLAR	SW-F19,彩锌	PCS	1
4	TBFE0925	ES3238006	六角法兰面螺母,M10*1.25	NUT M10×1.25	GB/T 6187.2,三价白	PCS	1
5	F19-45010-0	ES3353506	左握把	L. GRIP	SW-F19	PCS	1
6	F19-45010-0	ES3353512	油门握把	R. GRIP	SW-F19	PCS	1
7	F19-45030-0	ES3411502	左平衡块	BALANCING L	SW-F19,铝合金	PCS	1
8	F19-45030-0	ES3411503	右平衡块	BALANCING R	SW-F19,铝合金	PCS	1
9	F19-34400-0	ES3411504	油门座	THROTTLE PEDESTAL	中沙通用	PCS	1
10	F19-46010-0	ES3480023	油门拉线	THROTTLE CABLE	SW-F19	PCS	1
11	F19-3480024	ES3480024	调速把	SPEED GOVERNOR	SW-F19,电动	PCS	1
12		ES3480025	螺栓 M6*16	BOLT M6×16	SW-F19,电动	PCS	2

F2 左、右闸把 R.-L.S/W ASSY

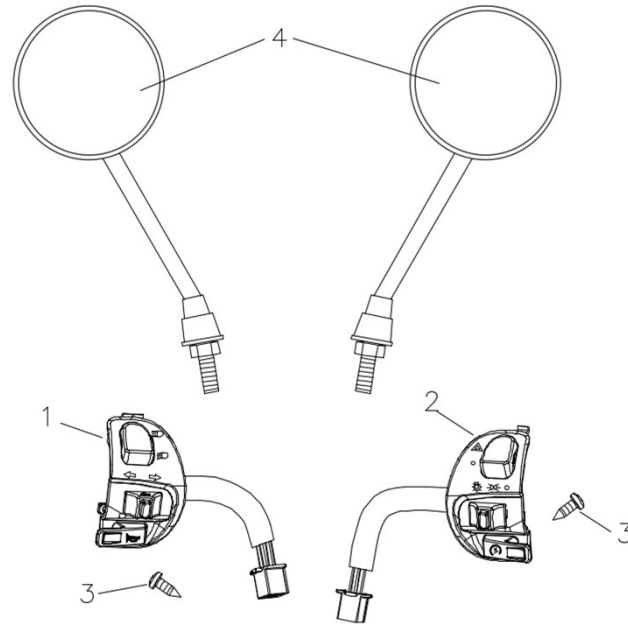

序号 No.	品号 Part No.	中文名称 Description	英文名称 Description	规格 SPCE.	单位 Unit	数量 Qty	备注 Remark	
1	F19-34100-0	ES3410049	左组合开关	LEFT HANDLE SWITCH ASSY.	SW-F19	PCS	1	
2	F19-34300-0	ES3410052	右组合开关	RIGHT HANDLE SWITCH ASSY	SW-F19,大灯常亮	PCS	1	
3	GBT845ST	ES3230356	自攻螺钉,ST4.8*12	SCREW ST4.2×16	GB/T 2823,三价白	PCS	2	
4	QBV-81710-0000A	ES3561088	后视镜组件,华洋HYT-1147,I E4-000125	REARVIEW MIRROR ASSY.	镀铬龟款,正反牙	PCS	1	

F3 前叉总成 FRONT FORK

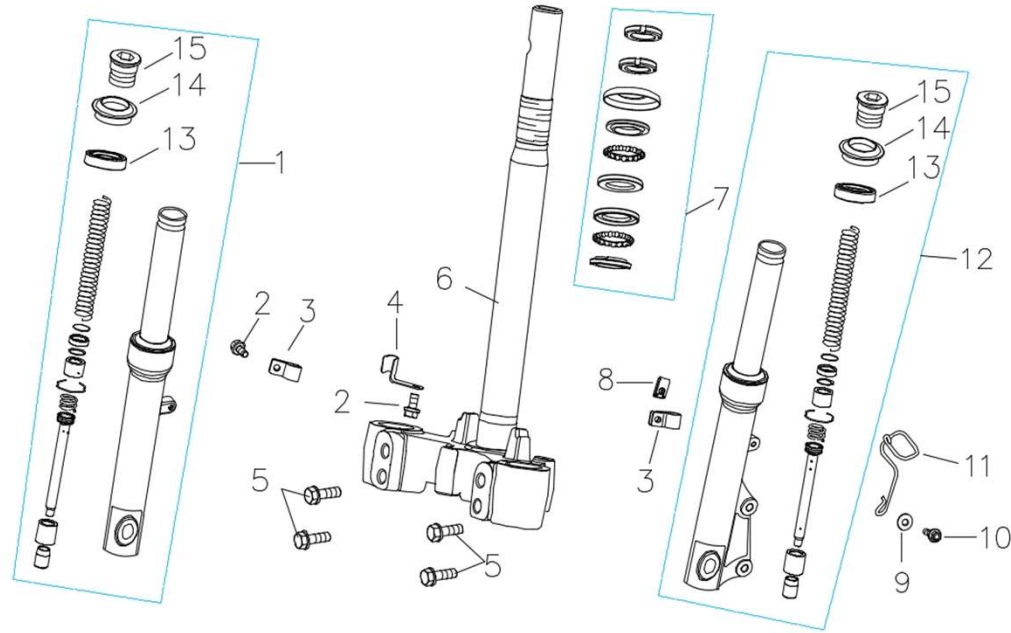

序号 No.	品号 Part No.	中文名称 Description	英文名称 Description	规格 SPCE.	单位 Unit	数量 Qty	备注 Remark	
1	F19-51520-0	ES3510130	F19前右减震器总成	F.R. FORK ASSY.	Φ31,L402,银灰,轴孔Φ12	PCS	1	
2			六角法兰面螺栓,M6*12	FLANGE BOLT M6×12	GB/T 16674.1,三价白	PCS	2	
3		ES3429522	制动油管线夹	CABLE HOLDER	SW50QT-8M,电泳黑	PCS	2	
4		ES2550039	里程线上线夹	CABLE HOLDER	SW50QT-8M,电泳黑	PCS	1	
5		ES3230161	六角法兰面螺栓,M8*40	FLANGE BOLT M8×40	GB/T 16674.1,三价白	PCS	4	
6	F19-51200-0	ES3421558	方向柱	STEERING COLUMN	SW-F19,电泳黑	PCS	1	
7	F19-51300-0	ES3570001	钢碗组件	BALL RACE COMP.	SW125T-16	PCS	1	
8		ES3238062	夹板螺母,M6	NUT M6	三价白	PCS	1	
9		ES3250064	垫圈,6*18*1.5	GASKET,6*18*1.5	GB/T 96,三价白	PCS	1	
10		ES3230084	六角法兰面螺栓,M6*25	FLANGE BOLT M6×25	GB/T 16674.1,三价白	PCS	1	
11		ES3429542	前制动油管导线环	CABLE HOLDER,FRONT BRAKE TUBE	SW-F19,电泳黑	PCS	1	
12	F19-51510-0	ES3510131	F19前左减震器	F.L. FORK ASSY.	Φ31,L402,银白,轴孔Φ12	PCS	1	
13		ES3510132	螺塞	SHOCK ABSORBER COVER		PCS	2	
14		ES3510133	防尘圈	GASKET		PCS	2	
15		ES3510079	前减震油封	CABLE HOLDER 31*43*10.3	油封31*43*10.3	PCS	2	

F4 前轮总成 FRONT WHEEL ASSY

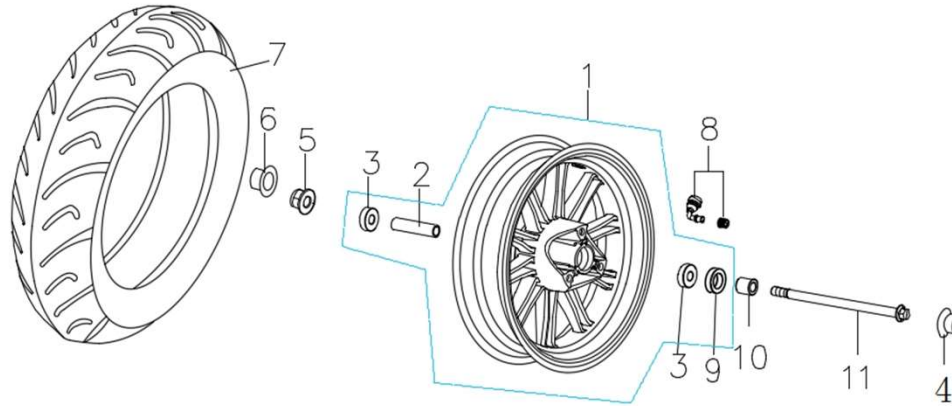

序号 No.	中文名称 Description	品号 Part No.	英文名称 Description	规格 SPCE.	单位 Unit	数量 Qty	备注 Remark
1	前铝轮	ES3500090	RIM COMP. 3.5×12,BLACK	碟刹,马尾鹰,,2.75*12,黑	PCS	1	
2	前轮中间隔套	ES3500138	BUSH	SW-F19,长20*38	PCS	2	
3	前轮轴承	ES3500135	BALL BEARING 6201-2RS	6201RS	PCS	1	
4	前轮轴防护帽	ES3356001	RUBBER CAP (14)	Φ14	PCS	1	
5	六角法兰面螺母,M12*1.25	ES3238011	NUT M12×1.25	GB/T 6187.2,镀彩锌	PCS	1	
6	前轮轴防护帽	ES3356002	RUBBER CAP (18)	Φ18	PCS	1	
7	轮胎	ES3502507	TIRE 120/70-12	真空,正新,C922,120/70-12,EEC,	PCS	1	
8	气门嘴,含帽	ES3503505	RIM VALVE COMP.	弯头	PCS	1	
9	前轮油封	ES3500134	OIL SEAL 22×37×7	22*37*7	PCS	1	
10	衬套	ES3287508	BUSH	Φ12*Φ20*32,彩锌	PCS	1	
11	螺栓轴,Φ12*230	ES3285012	FR. WHEEL AXLE M12×1.25×230	M12*1.25,彩锌	PCS	1	

F5 -1 前液刹总成 FRONT DISK BRAKE

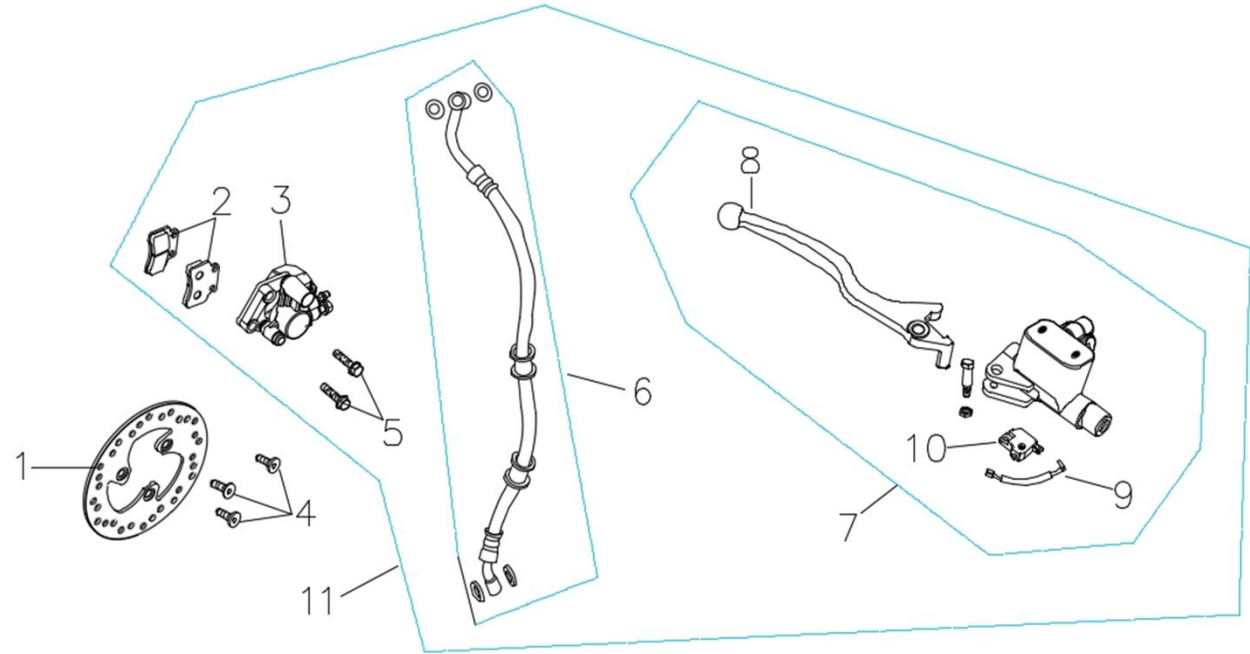

序号 No.	中文名称 Description	品号 Part No.	英文名称 Description	规格 SPCE.	单位 Unit	数量 Qty	备注 Remark
1	前制动盘	YYB950QT10014 ES3541003	FRONT BRAKE DISC Φ 180	圆盘,银,外径 Φ 180,厚4	PCS	1	
2	前制动蹄片(付)	QBY-56131-0000 ES3547037	BRAKE PAD KIT	SW50QT-K,B88,单缸	PCS	1	
3	前制动下泵	F19-56130-0 ES3547014	CALIPER ASSY(BLACK)	SW50QT-K,单缸,黑漆	PCS	1	
4	碟刹盘螺栓,M8*25*5	GBT2672-M8X25 ES3230383	BRAKE DISC BOLT M8*25*5	三价白,QBR-56002-0000	PCS	3	
5	碟刹下泵螺栓,M8*35	ES3230393	BOLT M8*35	GB/T 5789,8.8级,三价白	PCS	2	
6	前液刹油管	N-56120-0 ES3547119	FR.BRAKE HOSE	SW50QT-2L,全球鹰,橡胶管,总长960,上40下0度	PCS	1	
7	前制动上泵	F19-56110-0 ES3547076	CYLINDER COMP	SW50QT-3L,全球鹰	PCS	1	
8	前制动手柄	F19-56102-0 ES3547020	DISC BRAKE LEVER R.	SW50QT-8M,CHARGER,前后碟,黑色, ϕ 19	PCS	1	
9	液刹制动开关连接线(长300)	ES3547024	BRAKE SWITCH WIRELESS	SW50QT-M,F22	PCS	1	
10	前液刹制动开关	F17-56112-0 ES3547021	DISC BRAKE LEVER R.	SW50QT-M,F22,方	PCS	1	
11	前液压碟刹总成	ES3540115	FR.DISK BRAKE ASSY.	黑,橡胶管,单缸,手柄黑,球头 Φ 19	PCS	1	

F5-2 后液刹总成 REAR DISK BRAKE

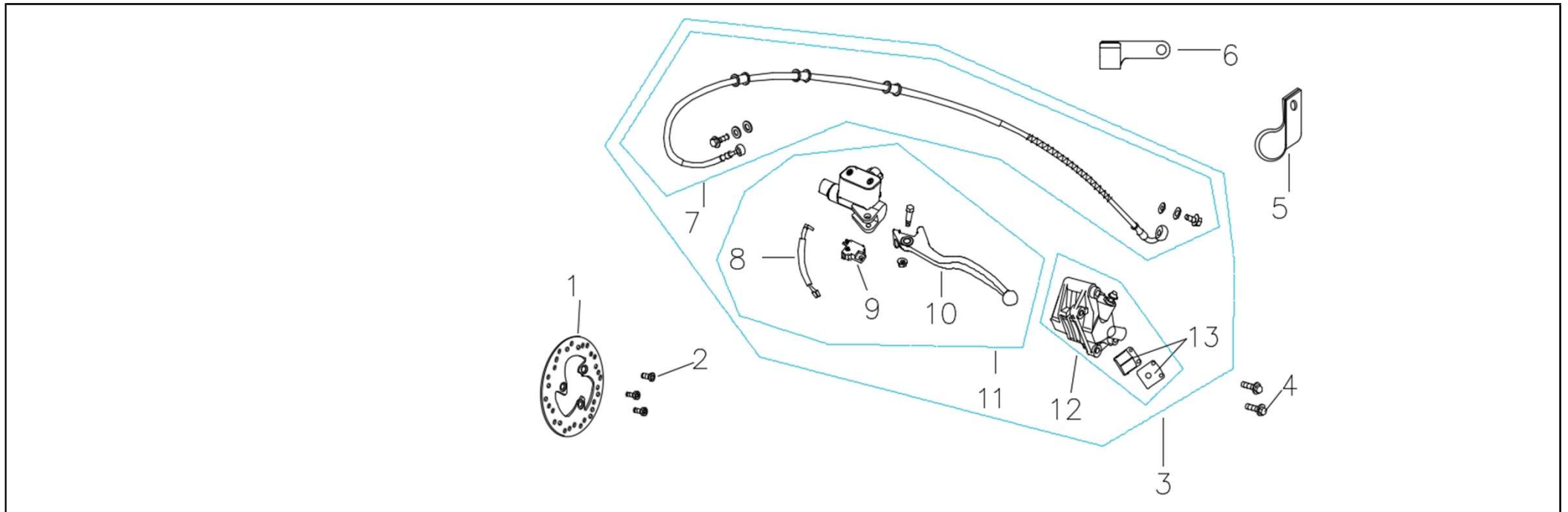

序号 No.	品号 Part No.	中文名称 Description	英文名称 Description	规格 SPCE.	单位 Unit	数量 Qty	备注 Remark	
1	TBFF0502B	ES3547076	后制动盘	REAR BRAKE DISC $\Phi 185$	圆盘,银,外径 $\Phi 185$,厚4	PCS	1	
2	GBT2672-M8X25	ES3547020	后碟刹盘螺栓,M8*25*5	BRAKE DISC BOLT M8*25*5	三价白,QBR-56002-0000	PCS	3	
3		ES3547021	后液压碟刹总成	FR.DISK BRAKE ASSY.	黑,橡胶管,单缸,手柄黑,球头 $\Phi 19$	PCS	1	
4		ES3230393	碟刹下泵螺栓,M8*35	BOLT M8*35	GB/T 5789,8.8级,三价白	PCS	2	
5			后液压油管固定座A	BRACKET A		PCS	1	
6	F19-51004-0	ES2550379	后液压油管固定座B	BRACKET B		PCS	1	
7	F17-3547145	ES3547145	后液刹油管 210mm	REAR BRAKE HOSE	编织管,总长210	PCS	1	
8		ES3547022	液刹制动开关连接线(长300)	BRAKE SWITCH WIRELESS	SW50QT-M,F22	PCS	1	防水插件
9		ES3547023	前液刹制动开关	DISC BRAKE SWITCH	SW50QT-M,F22,	PCS	1	
10	F17-57111-0	ES3547028	后制动手柄	REAR BRAKE LEVER		PCS	1	
11	F17-57110-0	ES3547029	后制动上泵总成	REAR BRAKE CYLINDER COMP	SW-F19	PCS	1	
12	F17-57130-0	ES3547010	后制动下泵总成	REAR BRAKE CALIPER ASSY.		PCS	1	
13	QBY-56131-0000	ES3547040	后制动蹄片(付)	REAR BRAKE PAD KIT (SET)		PCS	1	

F8 座垫总成 SEAT ASSY

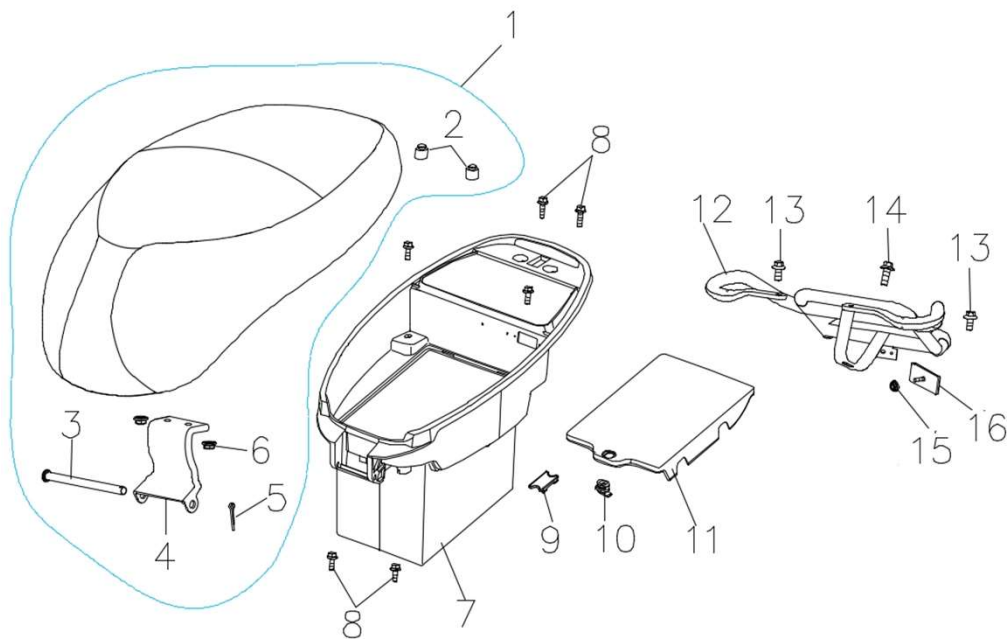

序号 No.	品号 Part No.	中文名称 Description	英文名称 Description	规格 SPCE.	单位 Unit	数量 Qty	备注 Remark
1	ES3460231	座垫总成	SEAT ASSY	F19,意大利皮黑	PCS	1	
2	ES3460232	座垫缓冲橡胶	SEAT RUBBER	Φ20*15	PCS	4	
3	ES3230365	座垫摇臂轴	BOLT, SEAT ARM	三价白	PCS	4	
4	ES3230366	座垫铰链	SEAT BRACKET	SW-F19	PCS	1	
5	ES3230367	摇臂轴挂销	LOCK PIN, SEAT ARM BOLT		PCS	1	
6	ES3230368	六角法兰面螺母,M6	FLANGE NUT M6	彩锌	PCS	2	
7	ES3450096	杂物箱	LUGGAGE BOX	SW-F19,PP,黑色	PCS	1	
8	GBT5787-M6X20	六角法兰面螺栓,M6*20	FLANGE BOLT M6*20	GB/T 16674.1,三价白	PCS	8	
9	ES3230088	座桶线卡	CLAP, LUGGAGE CABLE				
10	ES3230089	电池盖锁	LOCK, BATTERY COVER				
11	ES3230090	电池盖板	BATTERY COVER				
12	ES3455055	后货架	REAR CARRIER	SW-F19,电泳加喷塑黑	PCS	1	
13	ES3230131	六角法兰面螺栓,M8*16	FLANGE BOLT M8*25	三价白			
14	ES3230134	六角法兰面螺栓,M8*20	FLANGE BOLT M8*25	三价白			
15	ES3358531	六角法兰面螺母,M6	NUT M6				
16	QBK-32600-0000	后反射器	REAR FLECTOR				

F9 电机 MOTOR ASSY.

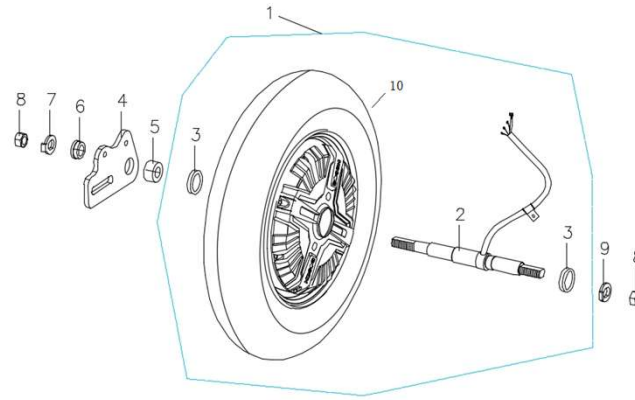

序号 No.	品号 Part No.	中文名称 Description	英文名称 Description	规格 SPCE.	单位 Unit	数量 Qty	备注 Remark
1	3230058	电机总成	MOTOR ASSY	GB/T 16674.1, 三价白	PCS	1	
2	ES2550055	电机轴 M16	AXLE, MOTOR M16	SW-F19, TREVIS, 电泳黑	PCS	1	
3	ES3238027	垫片	GASKET			2	
4	ES3454052	电机挂板	SUPPORT, MOTOR	SW-F19, 黑色	PCS	1	
5	ES3238021	隔套, M16	NUT M6	GB/T 6187.2, 镀彩锌	PCS	1	
6	ES3238022	弹簧垫片	SPRING WASHER				
7	ES3454034	电机卡销垫片	GASKET, MOTOR		PCS	1	
8	ES3230386	盖形六角头螺母, M16	NUT M16	镀白锌	PCS	3	
9	ES3454034	电机卡销垫片	GASKET, MOTOR		PCS	1	
10	ES3502511	后轮胎	REAR TIRE	真空, 正新, C922, 120/70-12, EEC	PCS	1	

F11-1车架总成 FRAME ASSY

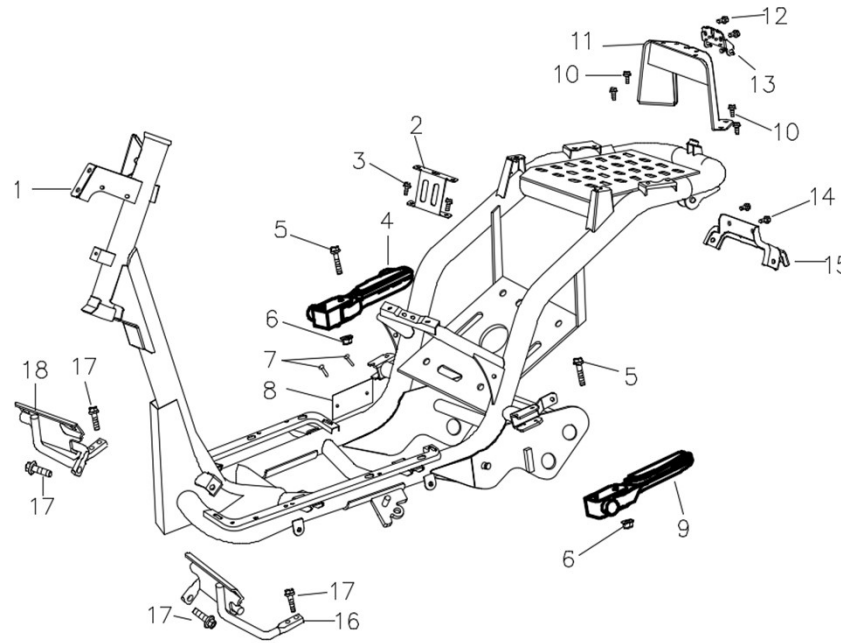

序号 No.	品号 Part No.	中文名称 Description	英文名称 Description	规格 SPCE.	单位 Unit	数量 Qty	备注 Remark	
1	ES3425504	ES3425504	车架	FRAME	SW-F19,3J3,EEC,电泳黑	PCS	1	
2		ES3481011	座桶支架	BRACKET, LUGGAGE	SW-F19	PCS	1	
3		ES3230322	六角法兰面螺栓,M6*12	FLANGE BOLT M6*12	GB/T 818,三价白	PCS	1	
4	ES3428544	ES3428544	右后脚踏组件	PEDAL ASSY R	SW-F19	PCS	1	
5		ES3226014	六角法兰面锁紧螺栓,M6*40	NUT M6	E,GB/T 6187.1,8级,彩锌	PCS	1	
6		ES3274001	自锁螺母	LOCK NUT	GB/T 12618 彩锌	PCS	1	
7			铆钉	RIVET		PCS	2	
8		ES4300002	铭牌	NAMEPLATE	铝	PCS	1	
9	ES3428544	ES3428543	左后脚踏组件	PEDAL ASSY L	SW-F19	PCS	1	
10		ES3230032	六角法兰面螺栓,M8*16	BOLT, M8*16	GB/T 16674.2,三价白	PCS	4	
11	ES3351503	ES3351503	后货架支架	BARACKET, REAR CARRIER	SW-F19	PCS	1	
12		ES3514070	坐垫锁螺栓 M6*12	BOLT, SEAT LOCK M6*12	SW-F19	PCS	2	
13	F19-47200-0	ES3238006	坐垫锁	SEAT LOCK		PCS	1	
14		ES3285002	螺栓, 后泥板支架 M6*16	BOLT, BRACKET, REAR FENDER M6*16		PCS	3	
15	ES3356501	ES3356501	后泥板支架	BRACKET, REAR FENDER	SW-F19	PCS	1	
16	ES3423222	ES3423222	左脚踏板支架	L BRACKET FOOTREST	SW-F19,电泳黑	PCS	1	
17	ES3230070	ES3230070	六角法兰面螺栓,M6*16	FLANGE BOLT M6*16	GB/T 16674.1,三价白	PCS	4	
18	ES3428024	ES3428024	右脚踏板支架	R BRACKET FOOTREST	SW-F19,电泳黑	PCS	1	

F11-1后平叉 REAR SWING ARM ASSY.

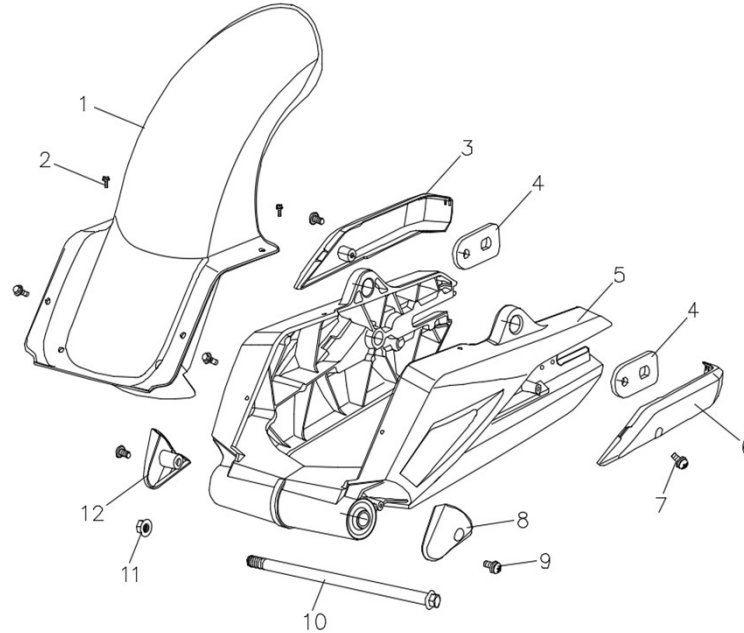

序号 No.	品号 Part No.	中文名称 Description	英文名称 Description	规格 SPCE.	单位 Unit	数量 Qty	备注 Remark
1	ES3425504	后泥板	REAR FENDER	SW-F19,3J3,EEC,电泳黑	PCS	1	
2	ES2530157	螺栓 M6*16	BOLT M6*16	SW-F19电喷,3J4,EEC,电泳黑	PCS	6	EFI
3	F17-1102028	右后, 后平叉装饰件	RR, DECORATIVE PARTS, REAR FORK	SW50QT-8M,CHARGER	PCS	1	
4	ES3230322	电机挂板	HANGING BOARD, MOTOR	GB/T 818,三价白	PCS	1	
5	F17-1102027	后平叉	REAR FORK	SW-F19	PCS	1	
6	F17-1102028	左后, 后平叉装饰件	LR, DECORATIVE PARTS, REAR FORK	E,GB/T 6187.1,8级,彩锌		1	
7	ES3274001	十字圆头螺栓 M5*16	CROSS BOLT M5*16	GB/T 12618		2	
8	F17-1102030	左前, 后平叉装饰件	LF, DECORATIVE PARTS, REAR FORK	无认证A,铝		1	
9	ES3428543	十字圆头螺栓 M5*16	CROSS BOLT M5*16	SW-F19		1	
10	QBK-52005-0000	吊架轴,Φ12*230	HANGING BOLT, Φ12*230	SW150T-4	PCS	1	
11	9214-M12X1-25-B	六角法兰面锁紧螺母,M12	NUT, M12	GB/T 16674.2,三价白	PCS	2	
12	F17-1102030	右前, 后平叉装饰件	RF, DECORATIVE PARTS, REAR FORK	SW150T-4,Φ20		2	

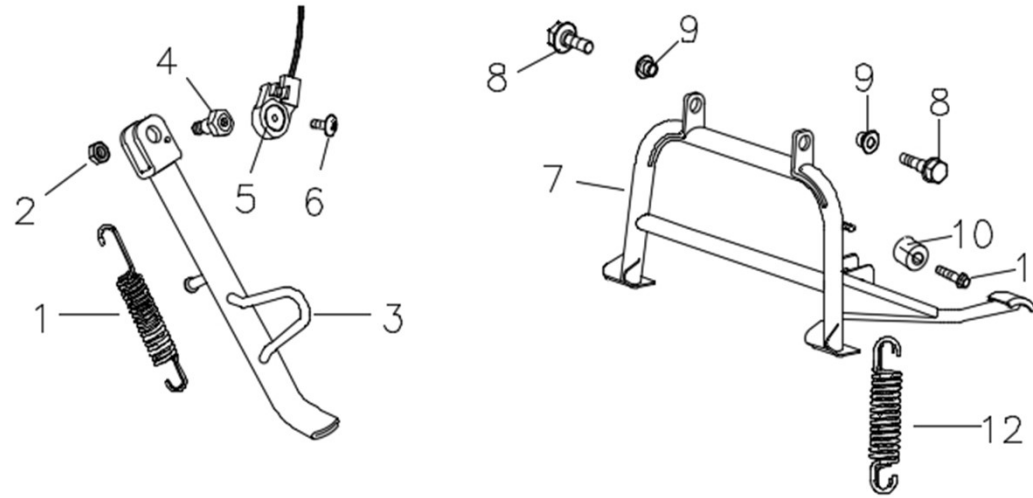

序号 No.		品号 Part No.	中文名称 Description	英文名称 Description	规格 SPCE.	单位 Unit	数量 Qty	备注 Remark
1	F17-41210-0	ES3391502	单撑弹簧	SPRING	SW50QT-M,F22,双弹簧,100,半圆180度,电泳黑	PCS	1	
3	ES3427051	ES3427051	单撑	SIDE STAND COMP.	SW-F19,电泳黑	PCS	1	
4	TB4F2008	ES3230371	单撑螺栓 M8	BOLT M8	三价白	PCS		
5	QBC-34500-0000A	ES3413002	单撑熄火开关	CUTOFF SWITCH	圆形	PCS	1	
6		ES3230363	十字大扁头螺栓,M6*16	TAPPING SCREW M6×16	盘头16,三价白	PCS		
7	F19-41320-0	ES2550337	双撑	MAIN STAND COMP.	SW-F19,3J3,宽踩杆高:205,电泳黑	PCS	1	
8		ES2550338	六角法兰面螺母,M8	NUT M8	GB/T 6187.2,三价白	PCS	1	
9	ES3287522	ES3287522	台阶衬套	ARMREST BUSH	Φ10.2*Φ16*Φ24*26*28,白锌		2	
10	F17-3428020	ES3428020	缓冲块	RUBBER		PCS	1	
11		ES3356503	六角法兰面螺栓,M6*35	FLANGE BOLT M6*35		PCS	1	
12	F17-41321-0	ES3392003	双撑弹簧	SPRING	双弹簧,90,电泳黑	PCS	1	

F13后减震总成 REAR SHOCK ABSORBER ASSY

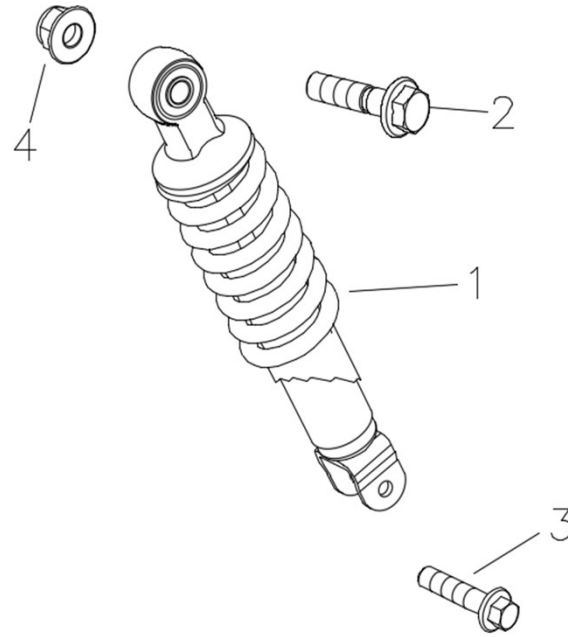

序号 No.	品号 Part No.	中文名称 Description	英文名称 Description	规格 SPCE.	单位 Unit	数量 Qty	备注 Remark
1	ES3512102	后减震器	RR. SHOCK ABSORBER(290)	290,黑弹簧,镀铬,750N	PCS	2	
2	ES3230023	六角法兰面螺栓,M10*1.25*40	FLANGE BOLT M10*1.25*40	GB/T 16674.2,三价白	PCS	1	
3	ES3230283	内六角螺钉,M8*35	HEX BOLT M8*35	GB/T 70.1,三价白	PCS	1	
4	ES3238006	六角法兰面螺母,M10*1.25	NUT M10*1.25	GB/T 6187.2,三价白	PCS	2	

F14前挡泥板 FRONT FENDER

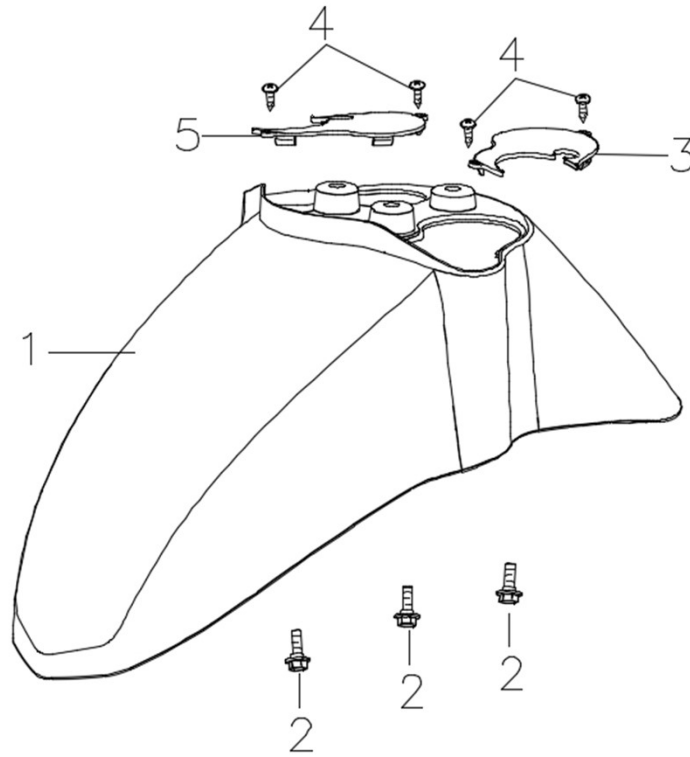

序号 No.		品号 Part No.	中文名称 Description	英文名称 Description	规格 SPCE.	单位 Unit	数量 Qty	备注 Remark
1	ES3445046	ES3445046	前挡泥板	FRONT FENDER	SW-F19, ABS	PCS	1	
2	9111-M6x16	ES3230365	六角法兰面台阶螺栓, M6*16*3	STEPS BOLT M6*16*3	三价白	PCS	3	
3	ES3445047	ES3445047	前挡泥板左小盖	FRONT FENDER COVER L	SW-F19, ABS	PCS	1	
4	GBT845ST4	ES3230352	自攻螺钉, ST4. 2*12	SCREW ST4. 2*12	GB/T 2823, 三价白	PCS	4	
5	ES3445047	ES3445048	前挡泥板右小盖	FRONT FENDER COVER L	SW-F19, ABS	PCS	1	

F15方向把护罩总成 HANDLE COVER

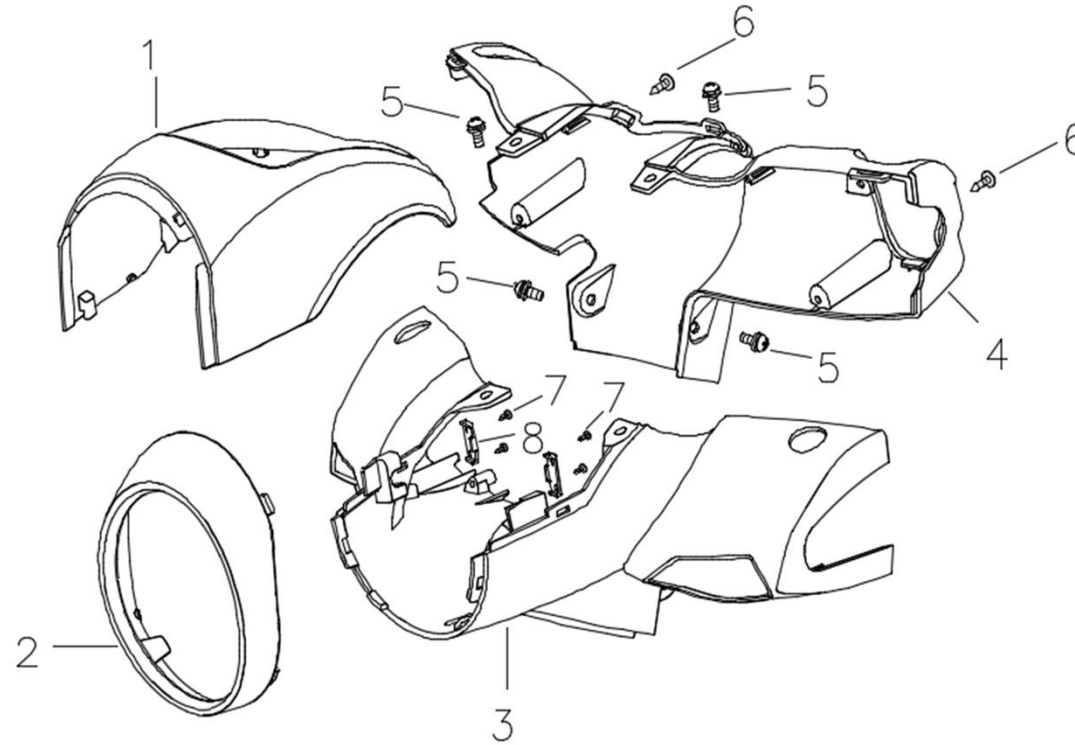

序号 No.	品号 Part No.	中文名称 Description	英文名称 Description	规格 SPCE.	单位 Unit	数量 Qty	备注 Remark	
1	ES344251	ES3442511	仪表罩	COVER METER	SW-F19,ABS	PCS	1	
2	ES3443567	ES3443567	大灯前罩	COVER HEAD LIGHT	SW-F19,ABS	PCS	1	
2-1		ES3443567-1	自攻螺钉,STM8*8	SCREW, COVER HEAD LIGHT ST2.8*8				
3	ES3441578	ES3441578	把手前罩	FRONT HANDLE COVER	SW-F19,ABS	PCS	1	
4	ES3443571	ES3443571	把手后罩	REAR HANDLE COVER	SW-F19,ABS	PCS	1	
5		ES3230580	十字槽盘头螺钉小垫圈组合M6*14	CROSS TROUGH PAN HEAD FLAT PAD SRECW M5*16	GB/T 9074.1,三价白	PCS	2	
6	GBT845ST4	ES3230352	自攻螺钉,ST4.2*12	SCREW ST4.2*12	GB/T 2823,三价白		2	
7		ES3230346	自攻螺钉,ST3*10	SCREW ST3*10	GB/T 2823,三价白		4	
8		ES3443572	前照灯压板	HEADLAMPS CLAMP	SW-F19,PP,黑色		2	

F16前面板总成 COVER.FB ASSY

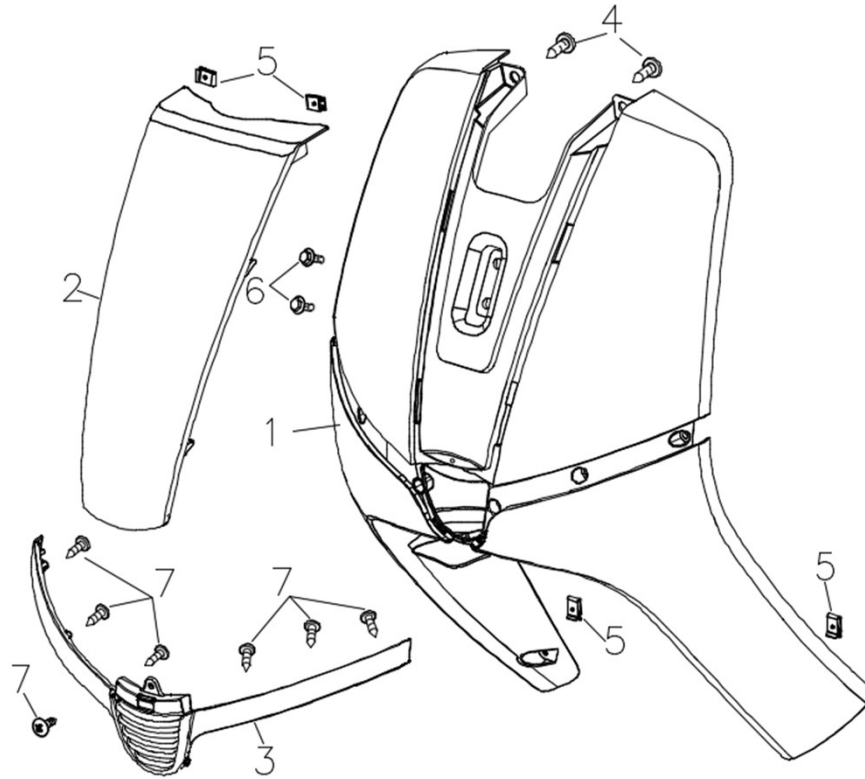

序号 No.	品号 Part No.	中文名称 Description	英文名称 Description	规格 SPCE.	单位 Unit	数量 Qty	备注 Remark
1	ES3443569	前面板	FRONT PANEL	SW-F19,ABS	PCS	1	1
2	ES3443568	前面板小盖	FRONT PANEL COVER	SW-F19,ABS	PCS	1	1
3	ES3443570	前面板装饰条	FRONT PANEL DECORATION	SW-F19,镀铬	PCS	1	1
4	9165-ST4-8x16-A	自攻螺钉,ST4.8*16	SCREW ST4.8*16	GB/T 2823,三价白	PCS	1	2
5	9221-M4-2x18x11-A	夹板,M4.2	SPRING NUT 4.2	三价白	PCS	1	2
6		六角法兰面台阶螺栓,M6*16*3	STEPS BOLT M6*16*3	三价白	PCS	1	2
7	GBT845ST4	自攻螺钉,ST4.2*12	SCREW ST4.2*12	GB/T 2823,三价白	PCS	1	7

F17脚踏板FOOTREST

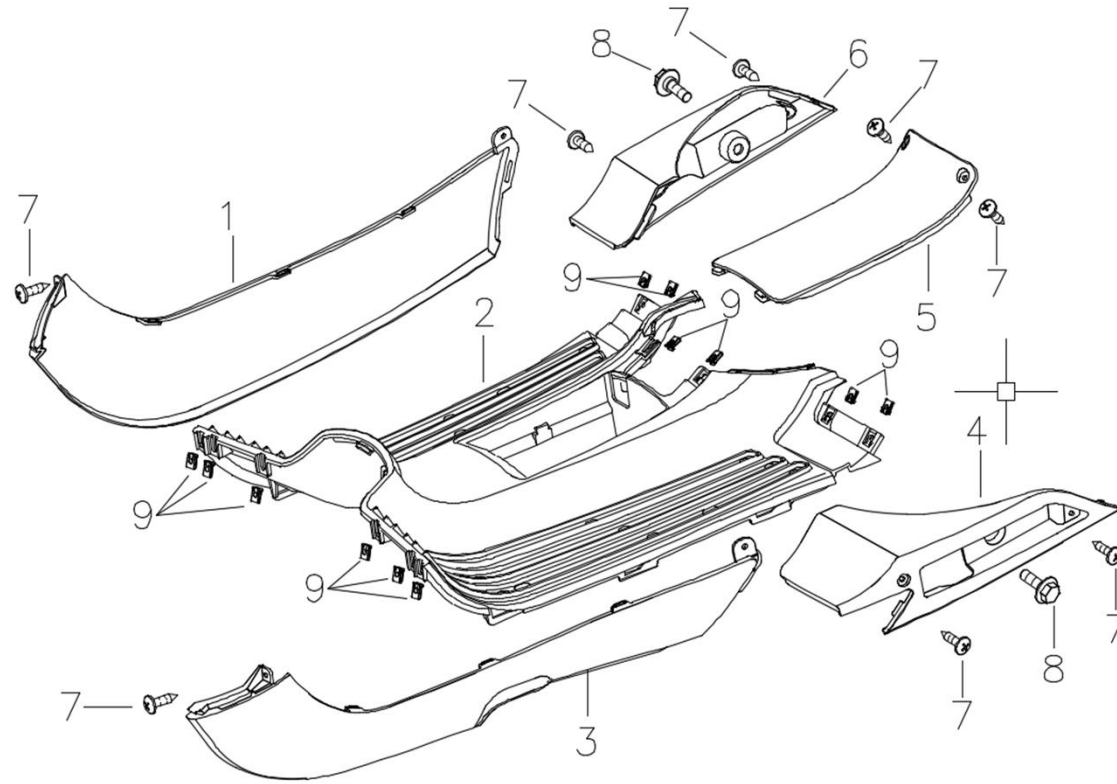

序号 No.	品号 Part No.	中文名称 Description	英文名称 Description	规格 SPCE.	单位 Unit	数量 Qty	备注 Remark	
1	ES3448541	ES3448541	右边条	RIGHT SIDE COVER	SW-F19,ABS	PCS	1	
2	ES3449075	ES3449075	脚踏板	FLOOR	SW-F19,ABS	PCS	1	
3	ES3448540	ES3448540	左边条	LEFT SIDE COVER	SW-F19,ABS	PCS	1	
4	ES3449077	ES3449077	后左脚踏装饰件	PEDAL DECORATION L	SW-F19,PP,黑色	PCS	1	
5	ES3449076	ES3449076	蓄电池盖	COVER,BATTERY	SW-F19,ABS	PCS	1	
6	ES3449077	ES3449078	后右脚踏装饰件	PEDAL DECORATION R	SW-F19,PP,黑色	PCS	1	
7	9165-ST4-8x16-A	ES3230358	自攻螺钉,ST4.8*16	SCREW ST4.8*16	GB/T 2823,三价白	PCS	8	
8		ES3230365	六角法兰面台阶螺栓,M6*16*3	STEPS BOLT M6*16*3	三价白	PCS	2	
9	9221-M4-2x18x11-A	ES3238060	夹板,M4.2	SPRING NUT 4.2	三价白	PCS	12	

F18前置物箱总成LEG SHIELD

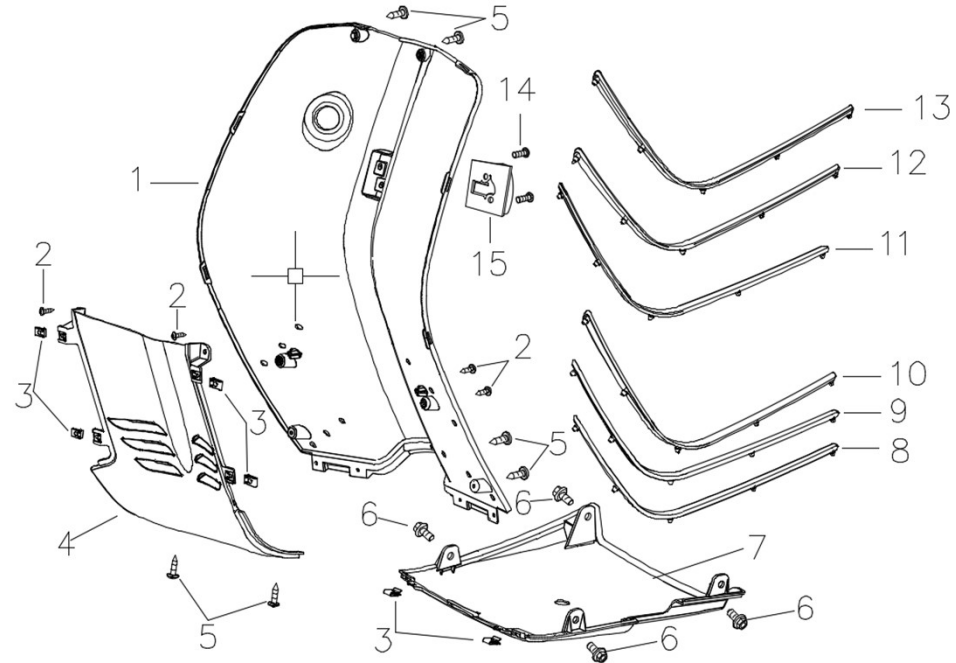

序号 No.	品号 Part No.	中文名称 Description	英文名称 Description	规格 SPCE.	单位 Unit	数量 Qty	备注 Remark
1	ES3445552	工具箱	LEG SHIELD	SW-F19, ABS	PCS	1	
2	GBT845ST4	自攻螺钉, ST4. 2*12	SCREW ST4. 2×12	GB/T 2823, 三价白	PCS	4	
3	9221-M4-2x18x11-A	夹板, M4. 2	SPRING NUT 4. 2	三价白	PCS	6	
4	ES3447538	车架挡泥板前部	INNER FENDER FR.	SW-F19, PP, 黑色	PCS	1	
5	9165-ST4-8x16-A	自攻螺钉, ST4. 8*16	SCREW ST4. 8×16	GB/T 2823, 三价白	PCS	6	
6		六角法兰面螺栓, M6*16	FLANGE BOLT M6*16	GB/T 16674. 1, 三价白	PCS	4	
7	ES3447539	车架挡泥板	INNER FENDER RR.	SW-F19, PP, 黑色	PCS	1	
8	ES3560509	脚踏皮条左1	FOOT SKIN L 1	SW-F19	PCS	1	
9		脚踏皮条左2	FOOT SKIN L 2	SW-F19	PCS	1	
10		脚踏皮条左3	FOOT SKIN L 3	SW-F19	PCS	1	
11		脚踏皮条右3	FOOT SKIN R 3	SW-F19	PCS	1	
12		脚踏皮条右2	FOOT SKIN R 2	SW-F19	PCS	1	
13		脚踏皮条右1	FOOT SKIN R 1	SW-F19	PCS	1	
14	ES3230336	十字槽盘头螺钉, M6*14	CROSS RECESS PAN HEAD SRECW M5*10	GB/T 818, 三价白		2	
15	ES3446542	头盔挂钩组件	HOOK, HELMET ASSY.	SW-F19, PP, 黑色		1	

F19后侧盖装饰件REAR DECOR PANEL

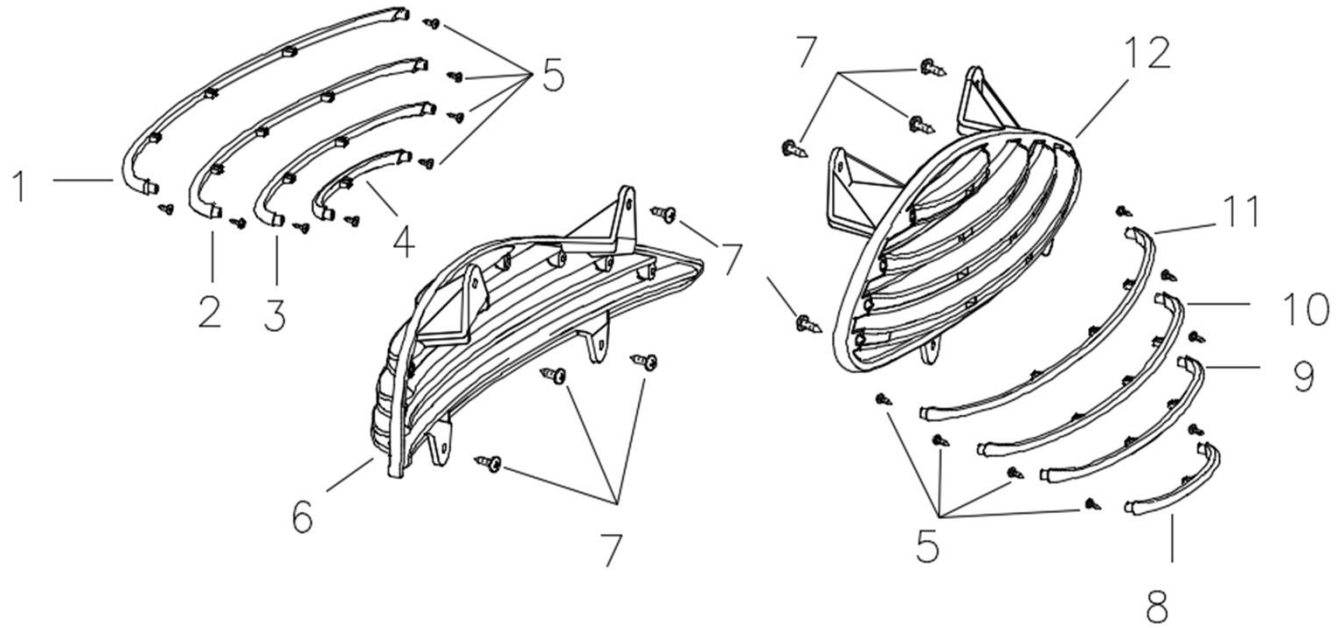

序号 No.	品号 Part No.	中文名称 Description	英文名称 Description	规格 SPCE.	单位 Unit	数量 Qty	备注 Remark	
1	ES3451190	ES3451186	后右侧盖装饰件1	REAR RIGHT DECOR PANEL1	SW-F19,镀铬	PCS	1	
2	ES3451190	ES3451187	后右侧盖装饰件2	REAR RIGHT DECOR PANEL2	SW-F19,镀铬	PCS	1	
3	ES3451190	ES3451188	后右侧盖装饰件3	REAR RIGHT DECOR PANEL3	SW-F19,镀铬	PCS	1	
4	ES3451190	ES3451189	后右侧盖装饰件4	REAR RIGHT DECOR PANEL4	SW-F19,镀铬	PCS	1	
5	GBT845ST4	ES3230352	自攻螺钉,ST4.2*12	SCREW ST4.2×12	GB/T 2823,三价白	PCS	8	
6	ES3451190	ES3451190	后左侧盖装饰件	REAR RIGHT DECOR PANEL	SW-F19,PP,黑色	PCS	1	
7		ES3230346	自攻螺钉,ST3*10	SCREW ST3×10	GB/T 2823,三价白	PCS	16	
8	ES3451191	ES3451182	后左侧盖装饰件1	REAR LEFT DECOR PANEL1	SW-F19,镀铬	PCS	1	
9	ES3451191	ES3451183	后左侧盖装饰件2	REAR LEFT DECOR PANEL2	SW-F19,镀铬	PCS	1	
10	ES3451191	ES3451184	后左侧盖装饰件3	REAR LEFT DECOR PANEL3	SW-F19,镀铬	PCS	3	
11	ES3451191	ES3451185	后左侧盖装饰件4	REAR LEFT DECOR PANEL4	SW-F19,镀铬	PCS	20	
12	ES3451191	ES3451191	后右侧盖装饰件	REAR LEFT DECOR PANEL	SW-F19,PP,黑色			

F20左右侧盖总成 SIDE COVER

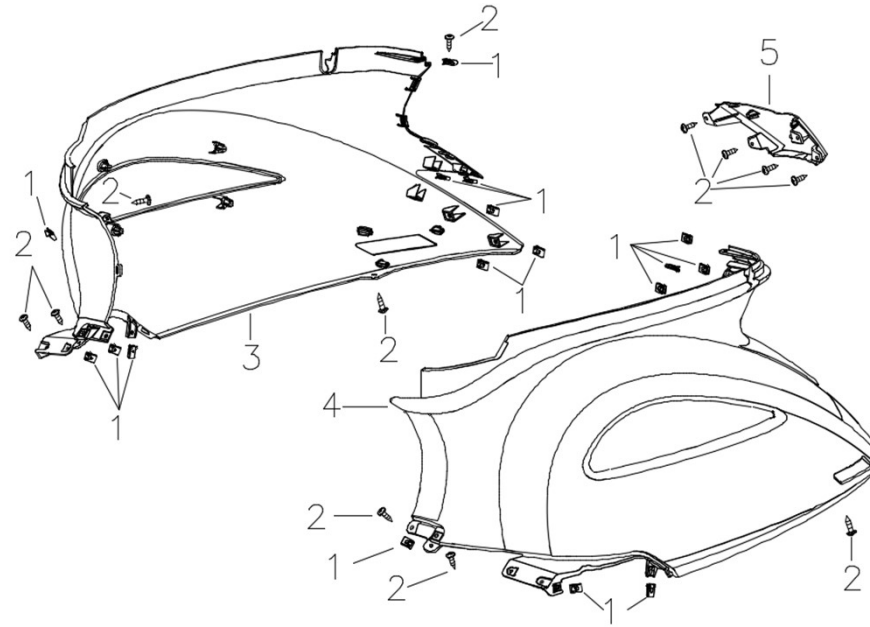

序号 No.	品号 Part No.	中文名称 Description	英文名称 Description	规格 SPCE.	单位 Unit	数量 Qty	备注 Remark
1	9221-M4-2x18x11-A	ES3238060 夹板,M4.2	SPRING NUT 4.2	三价白	PCS	17	
2	9165-ST4-8x16-A	ES3230358 自攻螺钉,ST4.8*16	SCREW ST4.8*16	GB/T 2823,三价白	PCS	12	
3	ES3451180	ES3451180 后左侧盖	COVER R.L.	SW-F19,ABS	PCS	1	
4	ES3451181	ES3451181 后右侧盖	COVER R.R.	SW-F19,ABS	PCS	1	
5	ES3453045	ES3453045 后中心盖	CENTER COVER RR.	SW-F19,ABS	PCS	1	

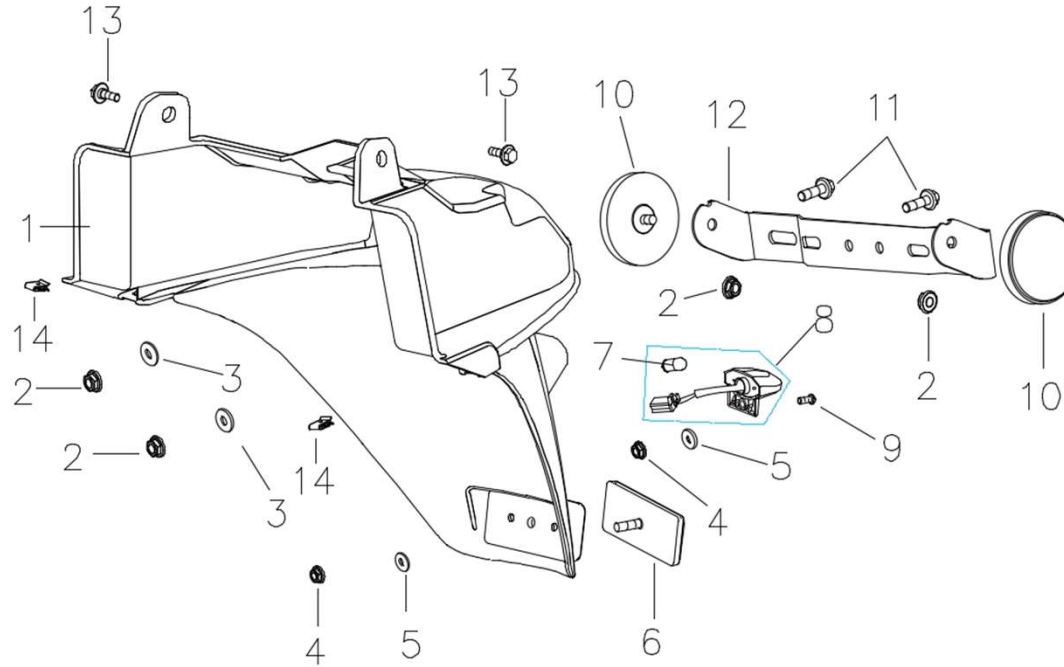

序号 No.	品号 Part No.	中文名称 Description	英文名称 Description	规格 SPCE.	单位 Unit	数量 Qty	备注 Remark
1	ES3454051	后挡泥板	FENDER RR.	SW-F19,PP,黑色	PCS	1	
2	ES3238027	六角法兰面螺母,M6	NUT M6	GB/T 6177.1,三价白	PCS	4	
3	ES3250064	垫圈,6*18*1.5	WASHER 6*18*1.5	GB/T 96,三价白	PCS	2	
4	ES3238024	六角法兰面螺母,M5	NUT M5	GB/T 6177.1,三价白	PCS	2	
5	ES3250058	垫圈,5*15*1.2	WASHER 5*15*1.2	GB/T 96,三价白	PCS	2	
6	QBK-32600-0000	后反射器	REAR RETRO REFLECTING DEVICE	百雪佳,E11-020613,M5	PCS	1	
7	ES3373005	售后,灯泡 W5W, 后牌照灯,插泡	BLUB	12V 5W	PCS	1	
8	QBH-32300-0000	后牌照灯	LICENSE PLATE LIGHT	SW50QT-H,GRIDO,E4-001091,	PCS	1	
9	ES3230327	十字槽盘头螺钉,M5*16	CROSS RECESS PAN HEAD SRECW M5*16	GB/T 818,三价白	PCS	1	
10	TK4F0604	侧反射器		科光,E9-02.1270,DOT	PCS	2	
11	ES3230070	六角法兰面螺栓,M6*16	FLANGE BOLT M6*16	GB/T 16674.1,三价白	PCS	2	
12	ES2550060	后牌支架	REAR LICENSE PLATE BRACKET	SW125T- 16,TREVIS,电泳黑,普通	PCS	1	
13	ES3230365	六角法兰面台阶螺栓,M6*16*3	STEPS BOLT M6*16*3	三价白	PCS	2	
14	9221-M4-2x18x11-A	夹板,M4.2	SPRING NUT 4.2	三价白	PCS	17	

F22仪表 SPEEDOMETER

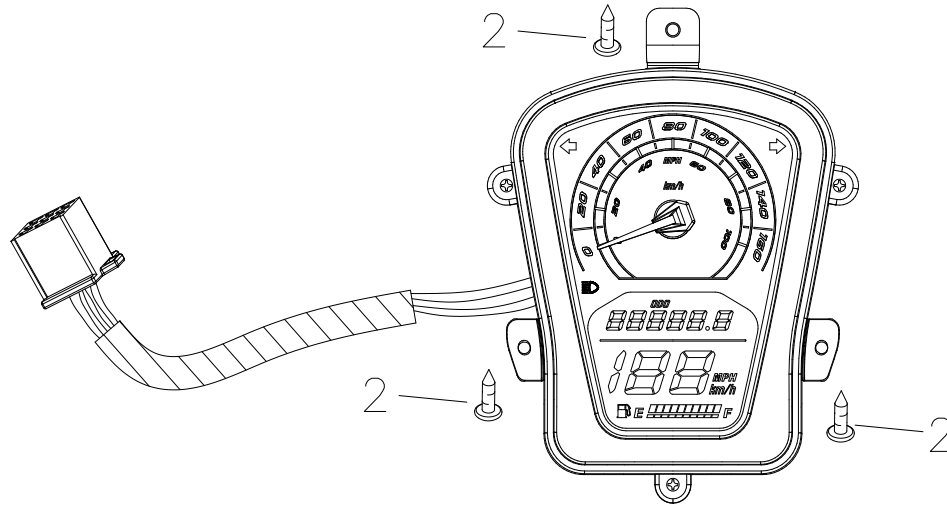

序号 No.		品号 Part No.	中文名称 Description	英文名称 Description	规格 SPCE.	单位 Unit	数量 Qty	备注 Remark
1	ES3400127	ES3400127	SW-F19,仪表	SPEEDOMETER	160km/h100mph	PCS	1	
2	GBT845ST4	ES3230352	自攻螺钉,ST4.2*12	SCREW ST4.2*12	GB/T 2823,三价白	PCS	3	

F23灯具 LIGHT ASSY.

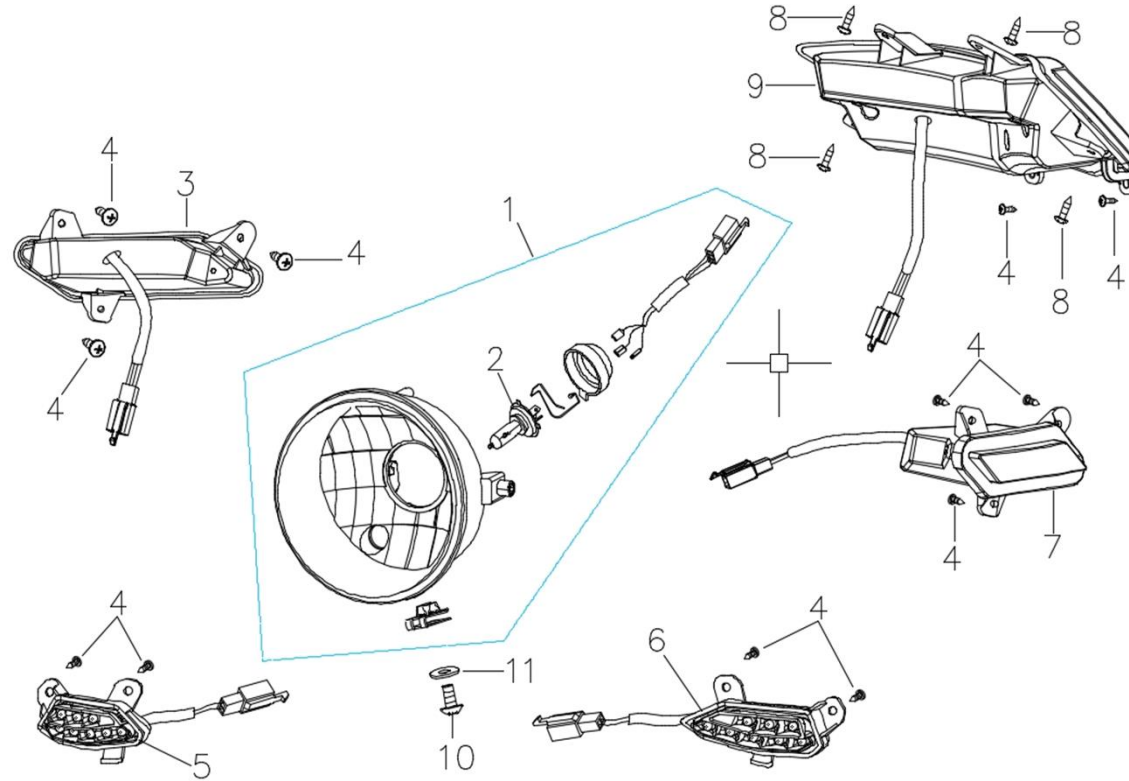

序号 No.	品号 Part No.	中文名称 Description	英文名称 Description	规格 SPCE.	单位 Unit	数量 Qty	备注 Remark	
1	ES3372085	ES3372085	前照灯	HEAD LIGHT ASSY.	SW-F19,E11-0134495	PCS	1	
2		ES3372038	售后,灯泡 HS1	BULB HEADLIGHT	12V 35W/35W	PCS	1	
3	ES3374142	ES3374142	后右转向灯	FLASHER LIGHT ASSY., RR	SW-F19,E11-0034497	PCS	1	
4	GBT845ST4	ES3230352	自攻螺钉,ST4.2*12	SCREW ST4.2*12	GB/T 2823,三价白	PCS	12	
5	ES3374144	ES3374144	前右转向灯	FLASHER LIGHT ASSY., FR	SW-F19,E11-0034496	PCS	1	
6	ES3374145	ES3374145	前左转向灯	FLASHER LIGHT ASSY., FL	SW-F19,E11-0034496	PCS	1	
7	ES3374143	ES3374143	后左转向灯	FLASHER LIGHT ASSY., RL	SW-F19,E11-0034497		1	
8	9165-ST4-8x16-A	ES3230358	自攻螺钉,ST4.8*16	SCREW ST4.8*16	GB/T 2823,三价白		4	
9	ES3373569	ES3373569	后尾灯	TAIL LIGHT ASSY.	SW-F19,E11-0034498		1	
10		ES3230054	六角法兰面螺栓,M6*10	HEX BOLT M6*10	GB/T 5789,三价白		1	

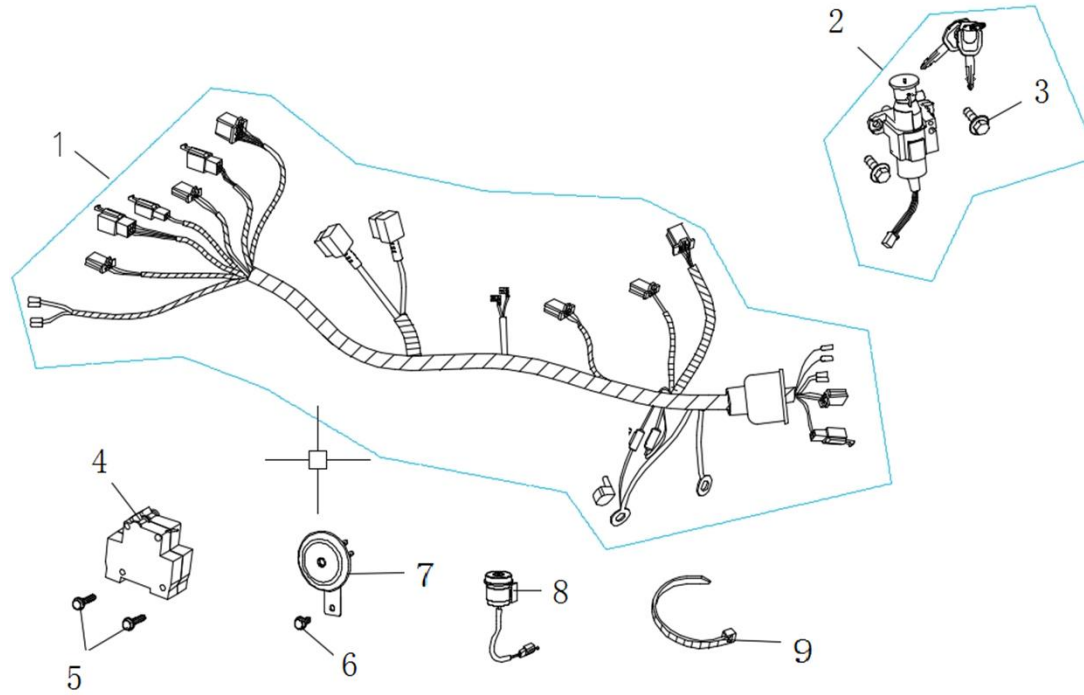

序号 No.	品号 Part No.	中文名称 Description	英文名称 Description	规格 SPCE.	单位 Unit	数量 Qty	备注 Remark
1	F19-31100-0	ES3370258	主电缆	WIRE HARNESS ASSY.	PCS	1	
2	F19-47100-0	ES3379505	套锁总成	LOCK ASSY	PCS	1	
3		ES3230058	法兰面螺栓,M6*16	HEX BOLT M6*16	PCS	2	
4	ES3377013	ES3377013	断电开关	AUSSCHALTER	PCS	1	
5		ES3379006	十字圆头螺栓M3*25	CROSS BOLT M3*25	PCS	1	
6		ES3230077	螺栓 M6*16	BOLT M6×16	PCS	1	
7	F17-3375503	ES3375503	喇叭	HORN	PCS	1	
8	F17-32800-0	ES3376512	圆形闪光器	FLASHER	PCS	1	
9		ES3375503	扎带	BELT	PCS	1	

F24-2电器总成 IELECTRICAL EQUIPMENT I

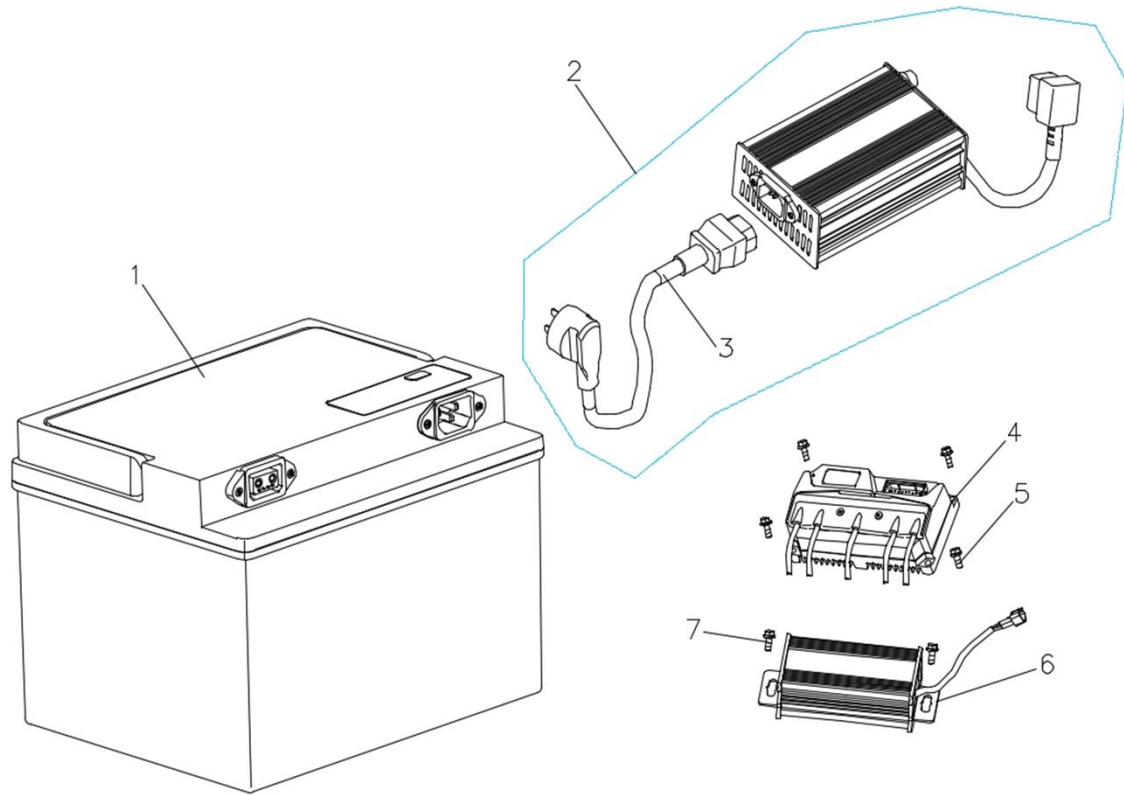

序号 No.	品号 Part No.	中文名称 Description	英文名称 Description	规格 SPCE.	单位 Unit	数量 Qty	备注 Remark
1	ES4415001	电瓶	BATTERY		PCS	1	
2	ES4415002	充电器总成 220V 4AH	CHARGER ASSY 220V 4AH	4*250, 黑	PCS	1	
3	ES3230469	充电线	WIRE, CHARGER	GB/T 70.1, 镀彩锌	PCS	1	
4	ES3230070	控制器	CONTROLLER	GB/T 16674.1, 三价白	PCS	1	
5	ES3383001	法兰螺栓 M6*20	FLANGE BOLT M6*20	SW125T-5, 标骑	PCS	4	
6	F17-3449083	转换器	CONVERT	SW-F19	PCS	1	
7	ES3370260	螺栓 M6*16	BOLT M6×16		PCS	2	